

EN

# Instruction manual

# OsmoTOUCH

Pure water at your fingertips

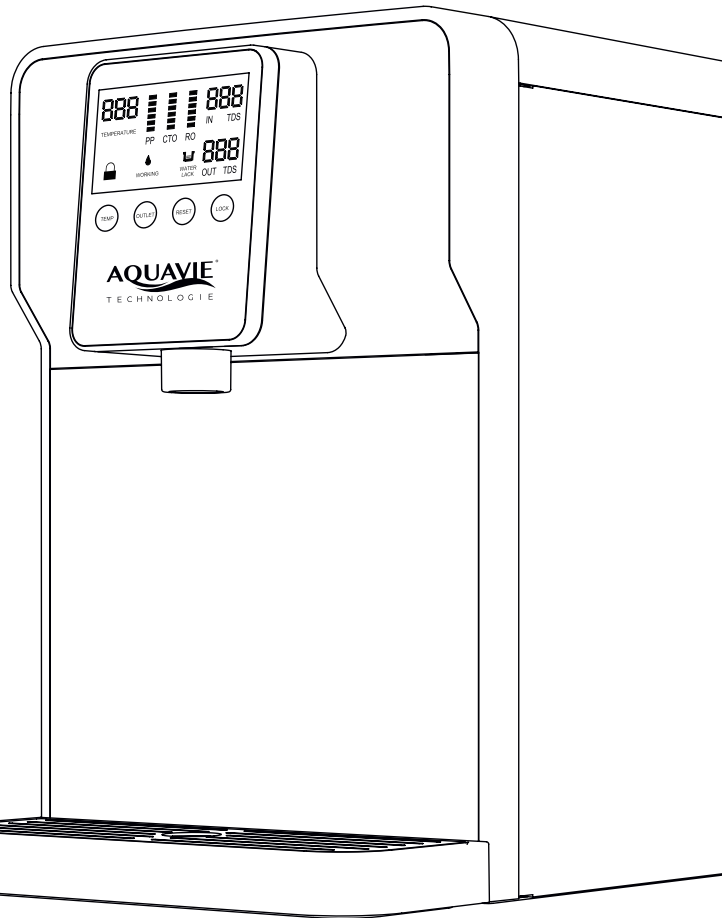

Countertop RO Water  
Dispenser

**AQUAVIE**<sup>®</sup>  
TECHNOLOGIE

Please read this instruction manual carefully before using the product and keep it properly.

# Content

1 - Product and Accessories	p 3
2 - Precautions for Use	p 4
3 - First time running suggestions	p 5
4 - Cartridge Replacement Period	p 5
5 - Cartridge Replacement Instruction	p 6
6 - Operation Instruction	p 7-8
7 - Functional Schematics	p 8
8 - Electrical Schematics	p 9
9 - Technical Specifications	p 9



# 1 – Product and Accessories

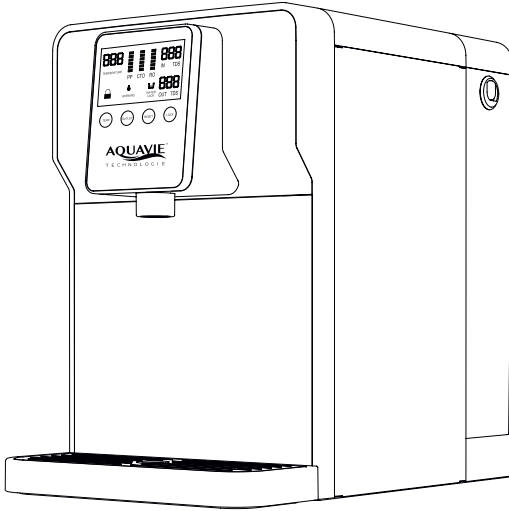

## One Main Body

Three Filter Cartridges-Includes spun PP filter(PP), block carbon filter(CTO), reverse osmosis membrane(RO)

## Instruction Manual

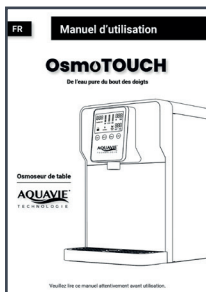

## Power Line

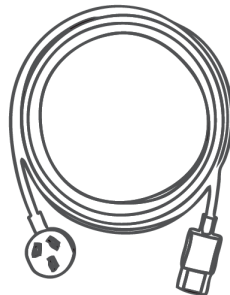

*Noted: Pictures are for reference only, subject to our available products.*

## 2 – Precautions for Use



1. The machine is only suitable for indoor installation and use. Please place it on flat table, and keep at least 15cm distance from wall.
2. Do not use power supply with disproportional rated voltage.
3. When running for the first time or without using for a long time, please clean the water tank and tubes by clean water.
4. Flush and replace cartridges regularly.
5. Please power off if the system won't be used for a long time.
6. It is forbidden to be operated by children to avoid scorching.
7. Do not use gasoline or any other organic solvents to wipe the machine. If it needs cleaning, please power off and then clean the surface of machine lightly with wet cloth .
8. Please cut off power and source water once troubles occur, and contact the local dealer service center.

## 3 – First time running suggestions

1. Open tank lid and pull tank out. Install filter cartridges into right position in order.

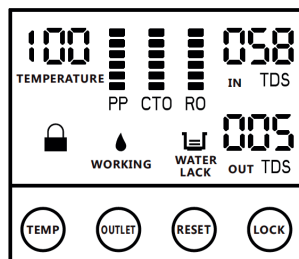
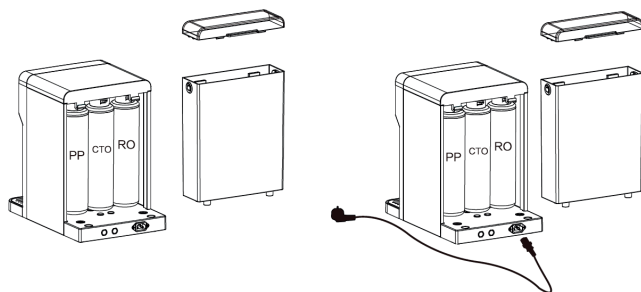

2. Connect to power.

3. Fill the tank with water, insert the tank and put lid back to its position.

4. After new filter cartridges get installed, flush them before use. Do as follows:

When icon  is off, press  to release all water in machine until icon  is on.



5. Repeat step 3&4 three times, then machine is ready to produce purified water for drinking.

**Caution:** When the machine has not been used for a long time, please do step 3&4 to flush filter cartridges before use.

## 4 – Cartridge Replacement Period

STAGES	FILTER CARTRIDGE	FUNCTION	LIFESPAN (FOR REFERENCE ONLY)
The first stage	Spun PP filter	Removes large suspended particles in water	3~6 months
The second stage	Block carbon filter	Further removes organics, chlorine, odor, color and turbidity	3~6 months
The third stage	RO membrane	Removes bacteria, heavy metals, dissolved matters and salinity	12~18 months

# 5 – Cartridge Replacement Instruction

1. Open tank lid and pull tank out.

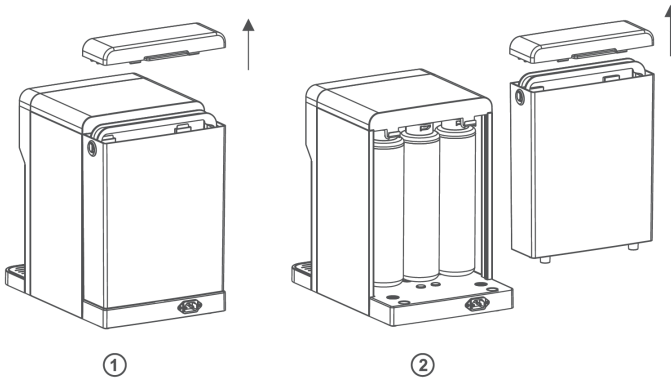

2. Lift up cartridge, rotate anticlockwise then remove it.

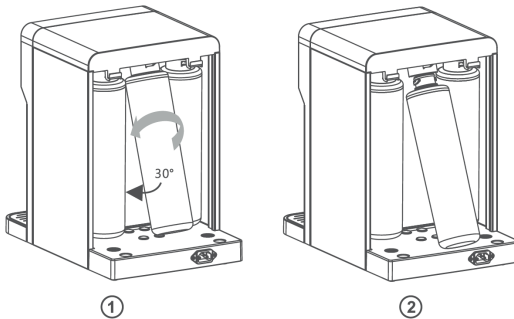

3. Rotate clockwise against the cap to install the cartridge, then fix the tank.

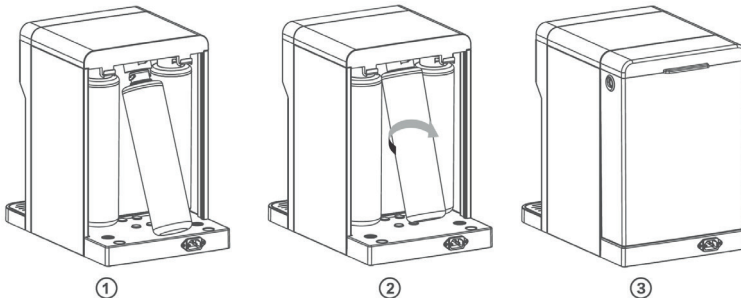

**Note: Please reset the filter element on the screen after replacement.**

# 6 – Operation Instruction

## 1. Starting up:

Connect machine with Power Line, the screen flashes three times and the buzzer rings three times. After that machine will start auto flush for 30seconds. Then booster pump starts working and machine starts producing purified water, at the same time the screen displays the TDS value of raw water and icon  is on.  
WORKING



After producing water for 30seconds, the screen updates and displays the TDS value of purified water.

When producing water ends, pump stops working and icon  is on.  
WORKING





During first time running, customer can only get pure water after finishing producing water.

## 2. Getting Water:





### a. Ambient Water

Press icon  to get water, and press icon  again to stop water.





### b. Boiled Water

Press icon , and press icon  to select Boiled Water, when icon  lights on, press icon  to get water, and press icon  again to stop water.

### c. Hot water

Press icon , and press icon  to select Boiled Water, when icon  lights on, press icon  to get water, and press icon  again to stop water.

### d. Lukewarm water

Press icon , and press icon  to select Boiled Water, when icon  lights on, press icon  to get water, and press icon  again to stop water.

### 3. Filter Cartridge Lifespan Reset:



There are 3 bandings to display the current lifespan of corresponding filter cartridge.

PP - preset time 360hours

CTO - preset time 360hours

RO - preset time 720hours

All bandings extinguish when Filter Cartridge's lifespan is over, with audible alarm 30times and flash.

After cartridge replacement, press  repeatedly until selected the replaced cartridge icon, then keep pressing  over 3seconds to reset new filter cartridge lifespan.

## 7 – Functional Schematics

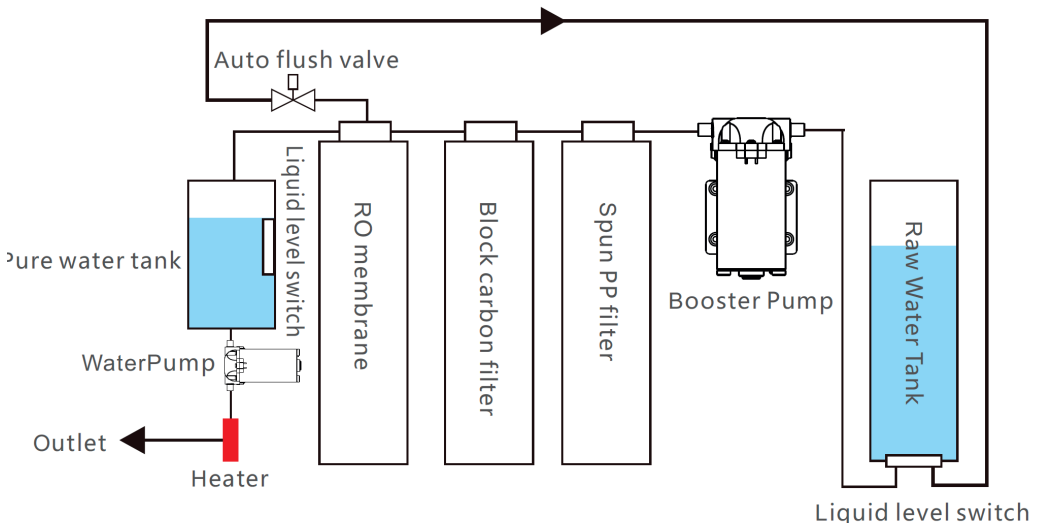



## 8 – Electrical Schematics

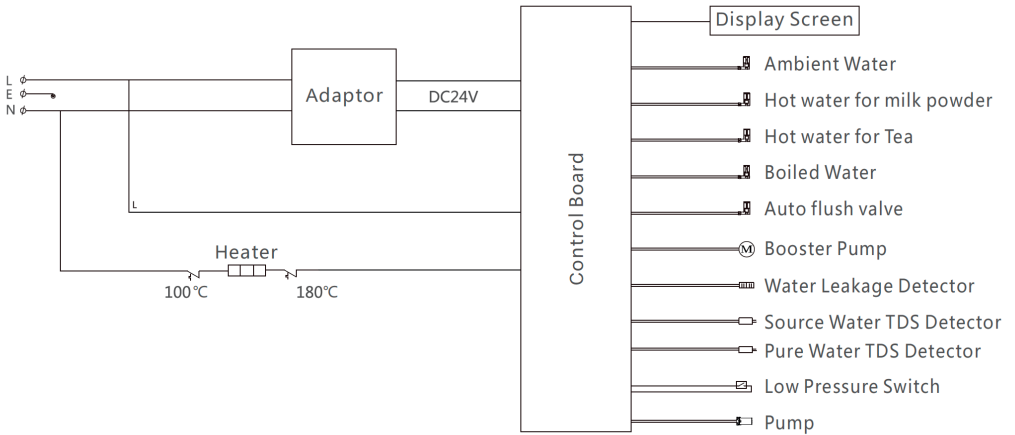

## 9 – Technical Specifications

**Feed water quality:** Municipal tap water

**Feed water temperature:** 5~45°C

**Voltage:** 220V

**Frequency:** 50/60Hz

**Total Rated Power:** 2200W

**Electric shock resistance:** type I

**Purified water flow:** 0.19L/Min

**Salt Rejection:** 92%~99%

**AQUAVIE**<sup>®</sup>  
TECHNOLOGIE



# AQUAVIE

TECHNOLOGIE

